

**Leica
Polarization
Slider**

V3 08/02/2010

B

B

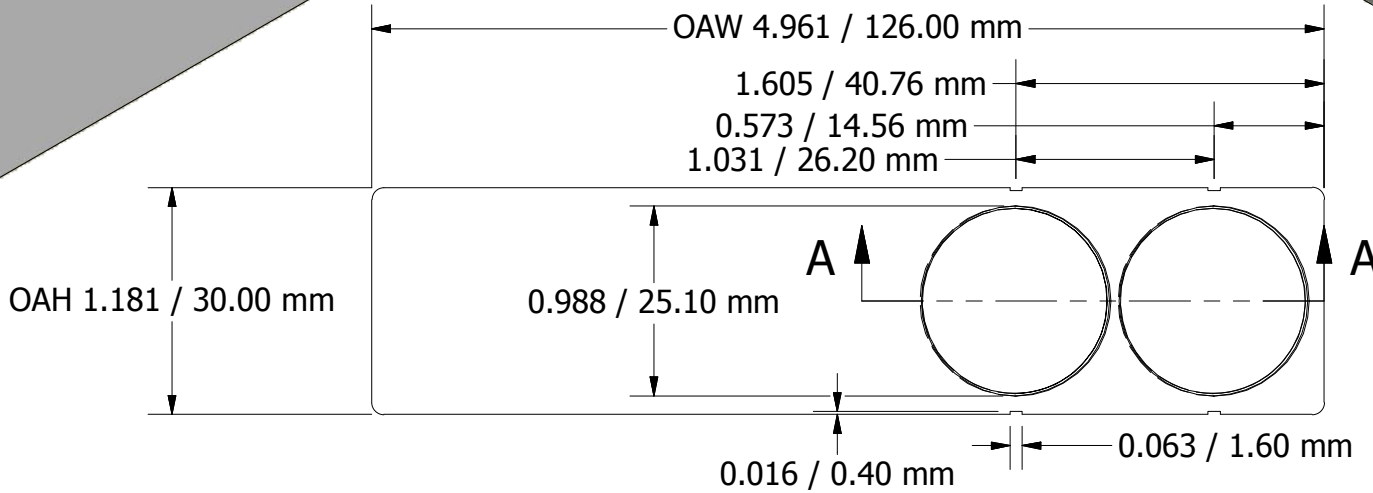
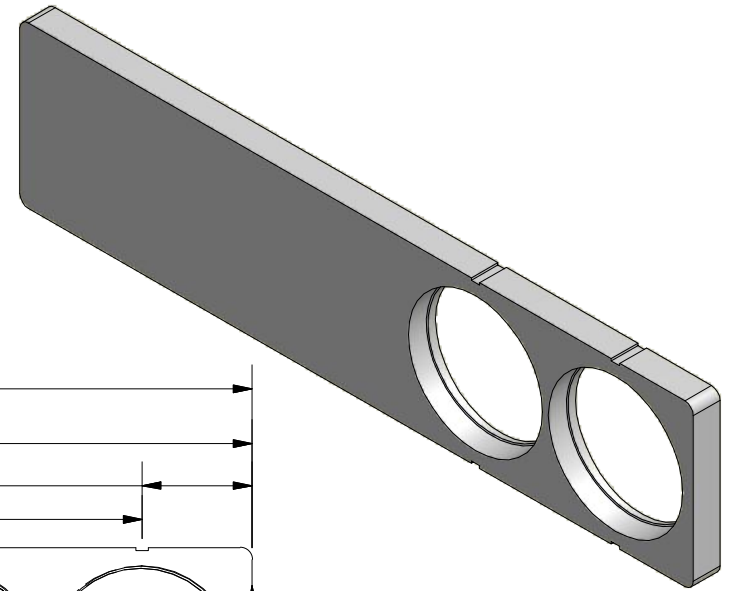
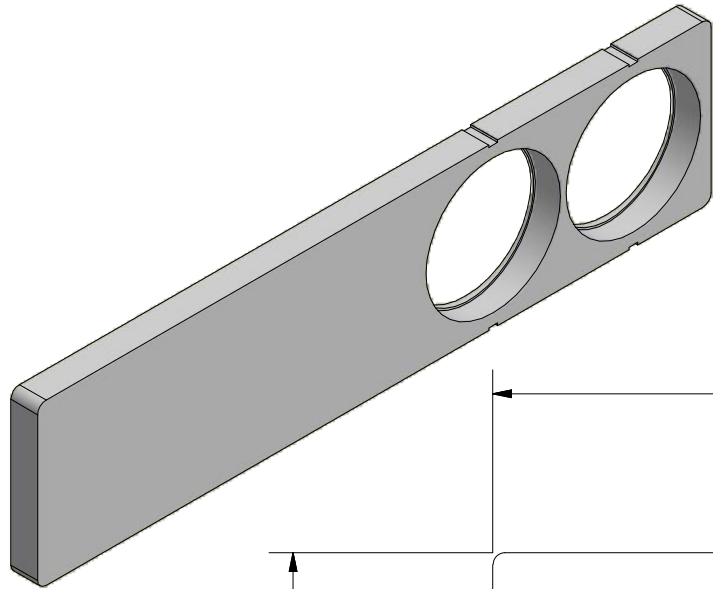

**SCALE
4:1**

A

A

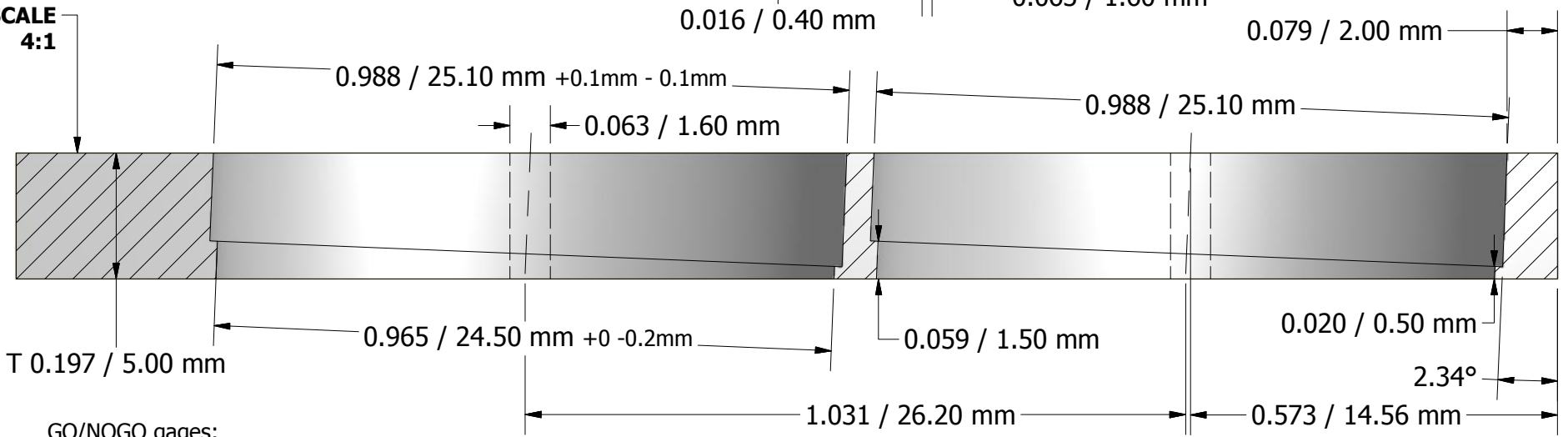

GO/NOGO gages:
 25.10mm +/- 0.1mm: GO=0.9843+ NOGO=1.0080-
 24.50mm +0 -0.2mm: GO=0.9567+ NOGO=0.9646-

Richard J Kinch, PhD -- Palm Beach County, Florida USA -- <http://www.truetex.com>
 leica_slider.idw

2

1

Leica Polarization Filter Slider CNC geometry

Use sine bar to elevate right edge for given angle.
Use sine bar for vise placement with parallels; remove before cutting.

